



Algae from Waste Water: A Dynamic Assessment of Potential

SAND#2011-8743C

AWRA 2011 Annual Water Resources Conference

Albuquerque, New Mexico

November 9, 2011

Jesse Roach, Geoff Klise, Howard Passell, Barbara Moreland,
Sandia National Laboratories, Albuquerque, NM, USA

Stephen O'Leary, Patrick McGinn
Institute for Marine Biosciences, NRCC, Canada;

Phil Pienkos
National Renewable Energy Laboratory, Golden, CO, USA;

David Batten
*Commonwealth Scientific and Industrial Research Organisation (CSIRO),
Australia*



Project Goals

- Address the question:

“What are the scales of algae cultivation that might be possible in different regions of Canada and Australia based on a geographic assessment of nutrient, solar, and land resources?”
- Create user friendly computer simulation models that:
 - allow users to evaluate and visualize algae cultivation and biocrude production capabilities in regions across Canada and Australia
 - allows users to change assumptions related to nutrient and energy availability and visualize updated output in real time
 - Provide insight into potential siting locations for pilot-scale plants



Project Approach

- Assume major nutrients (P, N, and C) necessary for algal growth will come from waste water treatment plants and industrial CO₂ sources.
- Collaborated with NRCC and CSIRO to gather data on P and N sources, large CO₂ sources, solar insolation, and land availability in select regions of Canada, and all of Australia. Assembled it into a geospatial database
- Developed a nutrient module based on stoichiometry of P, N, and C in nutrient sources, and algal requirements for them.
- Developed an energy module based on parameters in Weyer, Bush, Darzins, and Willson *Theoretical Maximum Algal Oil Production*, Bioenerg. Res. (2010) 3:204-213
- Combined these pieces in models with a graphic user interface

Model Components

Model Input Data:

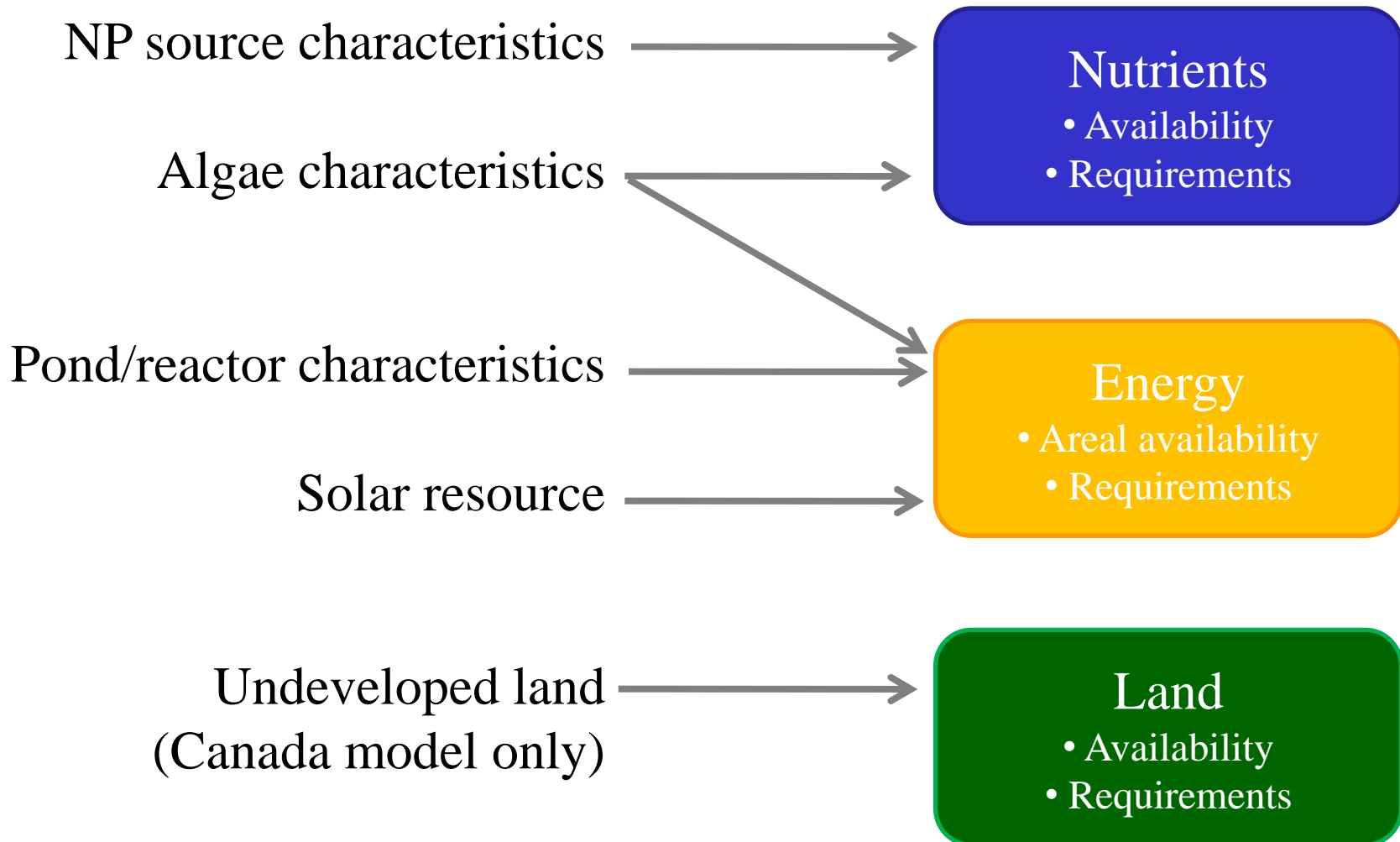







Nutrient Module Inputs

Algae Molecular Composition per Atom P

Adjust numbers in blue. Default for C, N, P is "Redfield ratio". Default for H and O compared to C from Bayless et al 2003.

P₁ O₅₉ N₁₆ C₁₀₆ H₁₉₁

Nutrient Uptake Efficiencies & Recycle Rates:

Nutrient	Uptake Efficiency	% Recycled
Nitrogen	100 % 	0 % 
Phosphorus	100 % 	0 % 
Carbon	100 % 	0 % 

If nitrogen load data are available, or phosphorus load data are available, but not both:

- Assume missing constituent is unlimited
- Do not calculate productivity potential for that nutrient source

User adjustable ratio of nutrient requirements

User adjustable nutrient uptake efficiency and % post harvest recycling

Nutrient Module Outputs

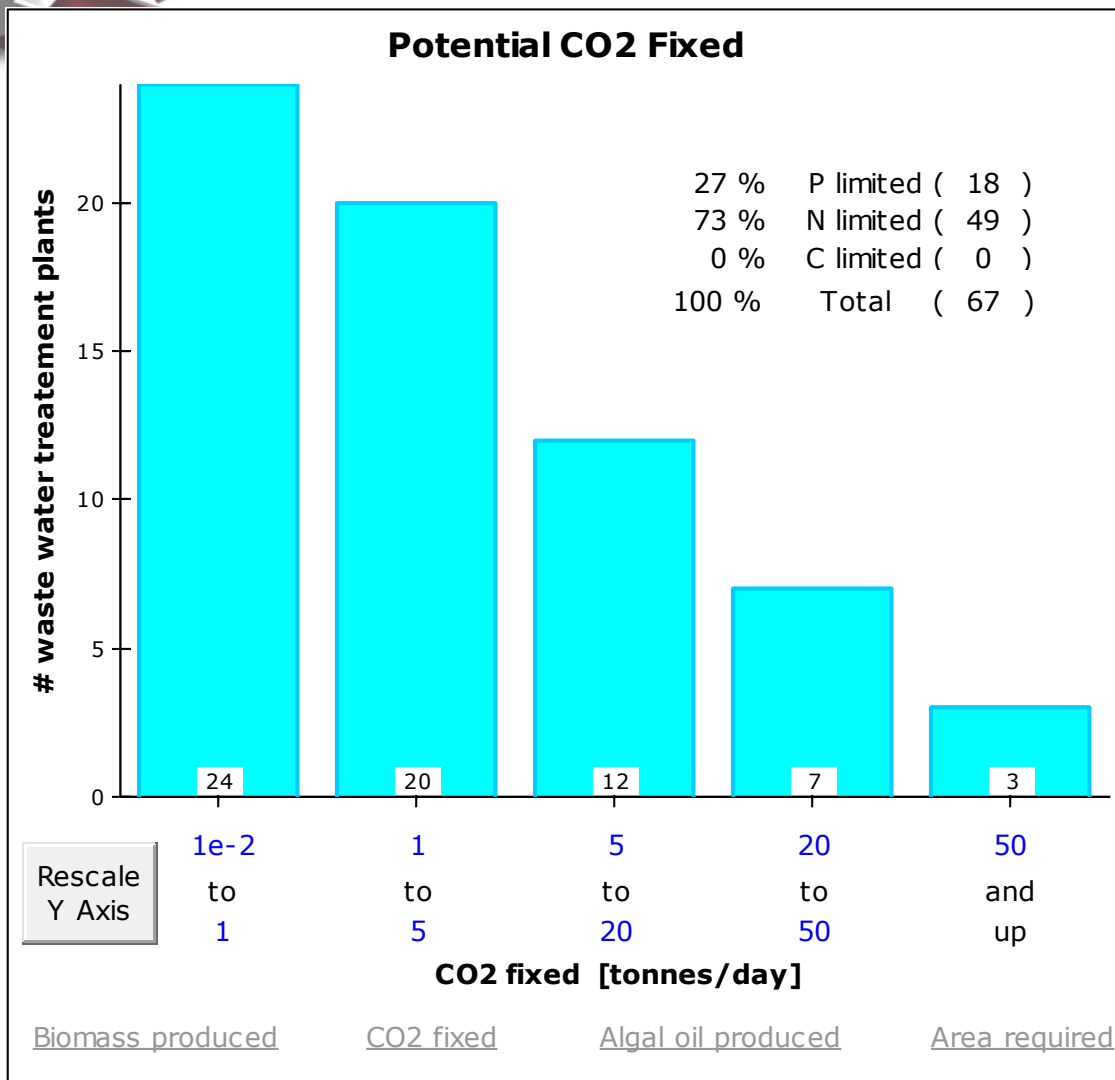

Histogram of # of wwtps that could produce a given range of biomass, or fix a given range of CO₂

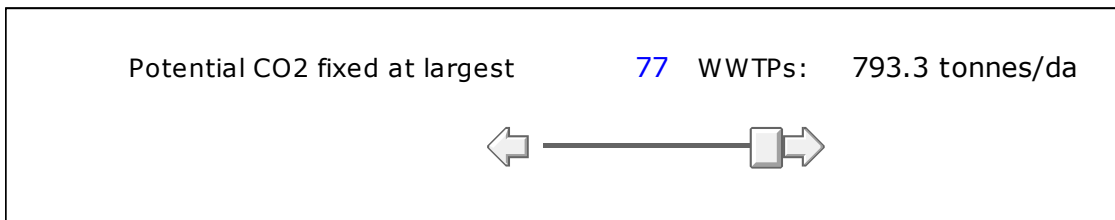

Nutrient Module Output Maps

Maps showing location and algal potentials of NP sources

Australia nitrogen and phosphorous (N&P) production locations colored according to potential algal biomass production for distance from N&P location to CO2 location of no more than **200 km**

Top 30 potential biomass production sites



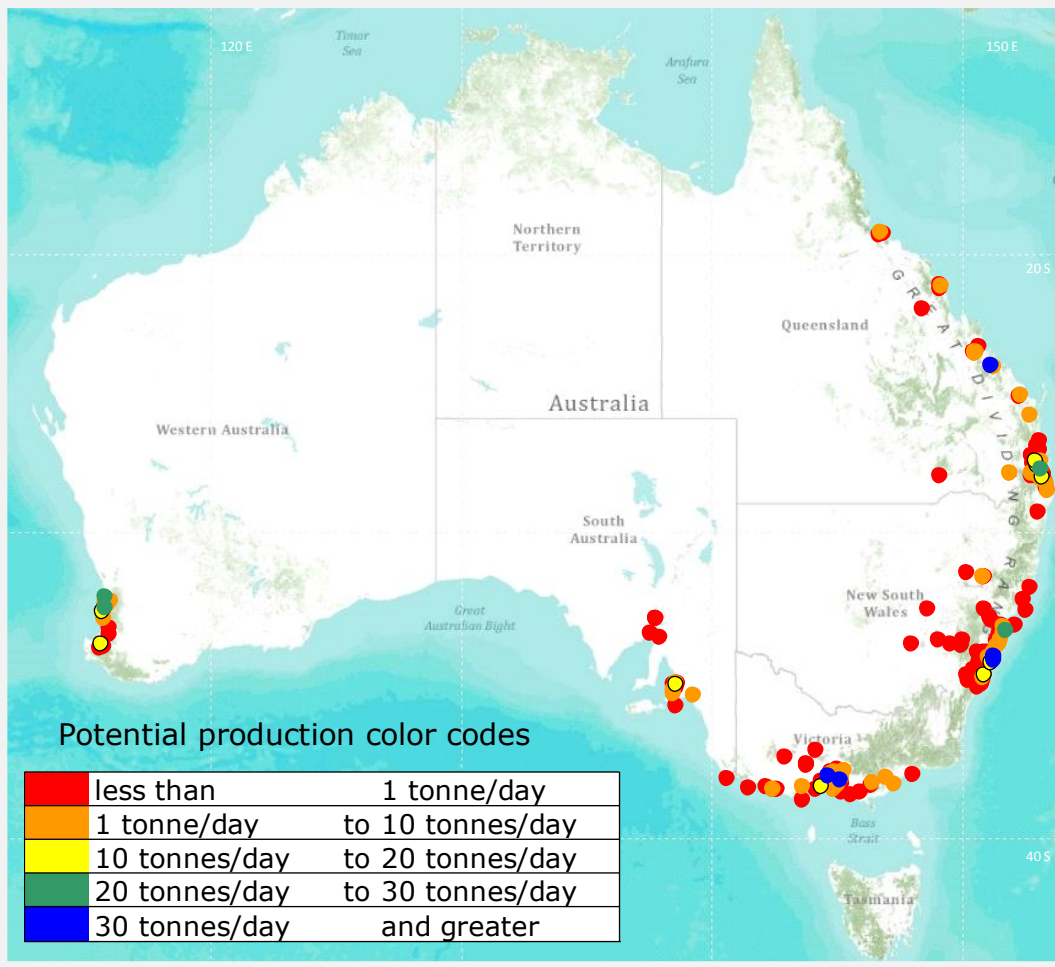

Malabar Sewage Treatment Plant	241 tonnes/day
Eastern Treatment Plant	239 tonnes/day
North Head Sewage Treatment Plant	200 tonnes/day
Western Treatment Plant	85 tonnes/day
Bondi Sewage Treatment Plant	75 tonnes/day
Rio Tinto Aluminium Yarwun	38 tonnes/day
Burwood Beach Wastewater Treatment Works	25 tonnes/day
Luggage Point WWTP	25 tonnes/day
Beenyup Wastewater Treatment Plant	24 tonnes/day
Woodman Point WWTP	23 tonnes/day
Bolivar Wastewater Treatment Plant	17 tonnes/day
Cronulla Sewage Treatment Plant	17 tonnes/day
Bunbury Wastewater Treatment Plant	12 tonnes/day
Black Rock Water Reclamation Plant	12 tonnes/day
Point Peron Wastewater Treatment Plant	12 tonnes/day
Murrumba Downs Sewage Treatment Plant	12 tonnes/day
Water Pollution Control Centre	11 tonnes/day
South Caboolture STP WRP	10 tonnes/day
Wollongong Sewage Treatment System	10 tonnes/day
Subiaco Wastewater Treatment Plant	10 tonnes/day
Oxley Creek Wastewater Treatment Plant	10 tonnes/day
Gibson Island WWTP	9 tonnes/day
Glenelg Wastewater Treatment Plant	7 tonnes/day
Cargill Meat Processors Tamworth	7 tonnes/day
Murray Bridge Wastewater Treatment Plant	6 tonnes/day
Queensland Alumina Ltd	6 tonnes/day
Brendale Sewage Treatment Plant	6 tonnes/day
Kincumber Sewage Treatment Plant	6 tonnes/day
Bribie Island Sewage Treatment Plant	6 tonnes/day
Warriewood Sewage Treatment Plant	5 tonnes/day

All N&P sources : 1,307 tonnes/day



Energy Module Inputs: Canada

Average Solar Resource by Region

Alberta 4,393 MJ/m ² /yr		Default values estimated by visual inspection of Plate 12B of Hydrological Atlas of Canada. Canada Dept of Fisheries & the Env. Atmospheric Env. Service, 1975 S Ontario: 115-120 Alberta & N Scotia: 100-110 BC: 90-105 KCal/cm ²
Nova Scotia 4,393 MJ/m ² /yr		
Southern Ontario 4,937 MJ/m ² /yr		
British Columbia 4,184 MJ/m ² /yr		

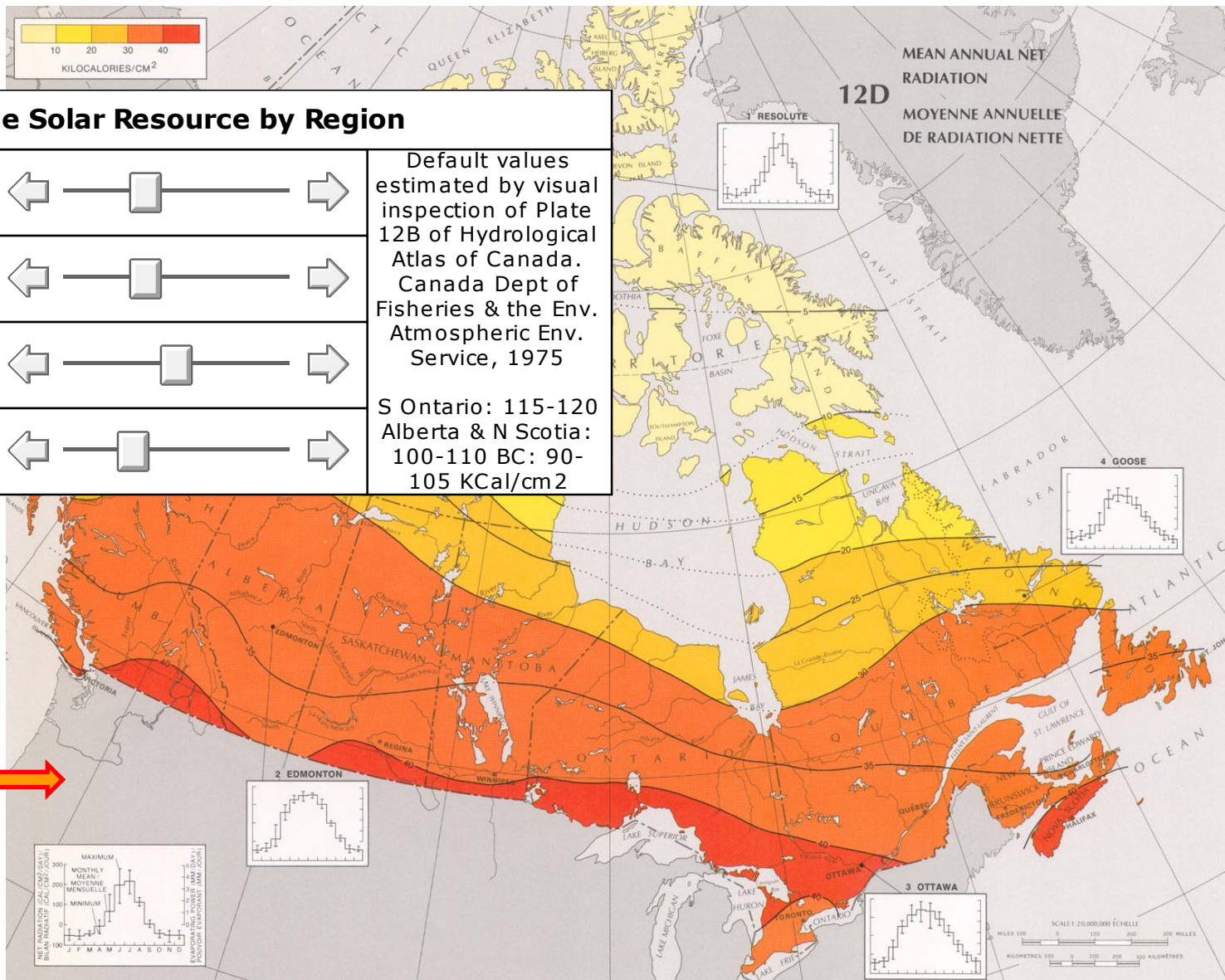

User adjustable solar resource estimates with defaults based on map to the right



Energy Module Inputs: Australia

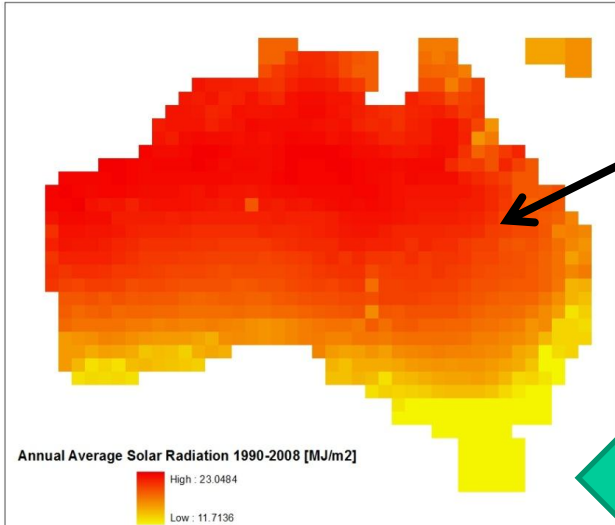

Converted to 1 degree data for computational efficiency



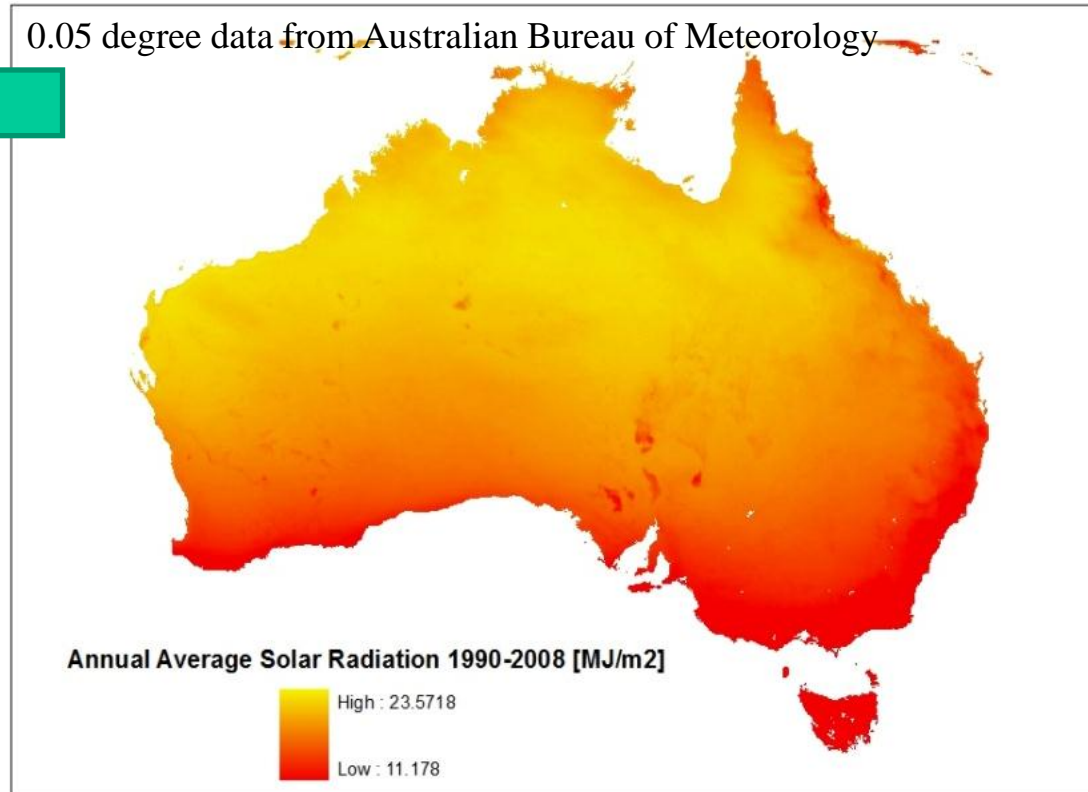

Location specific parameters	
SOLAR RADIATION <ul style="list-style-type: none"><input checked="" type="radio"/> Use spatially variable default values<input type="radio"/> Use 20 MJ/m²/day	SOLAR REFLECTION <ul style="list-style-type: none"><input checked="" type="radio"/> Use spatially variable default values<input type="radio"/> Use 7 %
<p>Solar resource default values are spatially distributed by degree based on Australian Government Bureau of Meteorology Annual Average Solar Exposure Data 1990-2008</p> <p>http://www.bom.gov.au/jsp/ncc/climate_averages/solar-exposure/</p> <p>Photon transmission % are % photons not lost to reflection. Default values as f(latitude) area based on extrapolation from Figure 4 in Weyer et al. (2010)</p>	

0.05 degree data from Australian Bureau of Meteorology



Energy Module Inputs continued

Algae and environment specific parameters		
Photon utilization efficiency	45 %	Parameters and default values based on Weyer, Bush, Darzins, and Willson 2010 "Theoretical Maximum Algal Oil Production"
Photosynth. quantum requirement	8	
Chemical energy in CH ₂ O	480 KJ/mol	
Biomass accumulation efficiency	50 %	
Biomass energy content	22 KJ/g	
Oil content of algal cells	40 %	
Algal oil density	918 kg/m ³	

Photon transmission % by region		
Alberta 75 %		% Photons not lost to reflection. Default values based on extrapolation from Figure 4 in Weyer, Bush, Darzins, and Willson 2010
Nova Scotia 85 %		
Southern Ontario 85 %		
British Columbia 80 %		

Energy Module Outputs

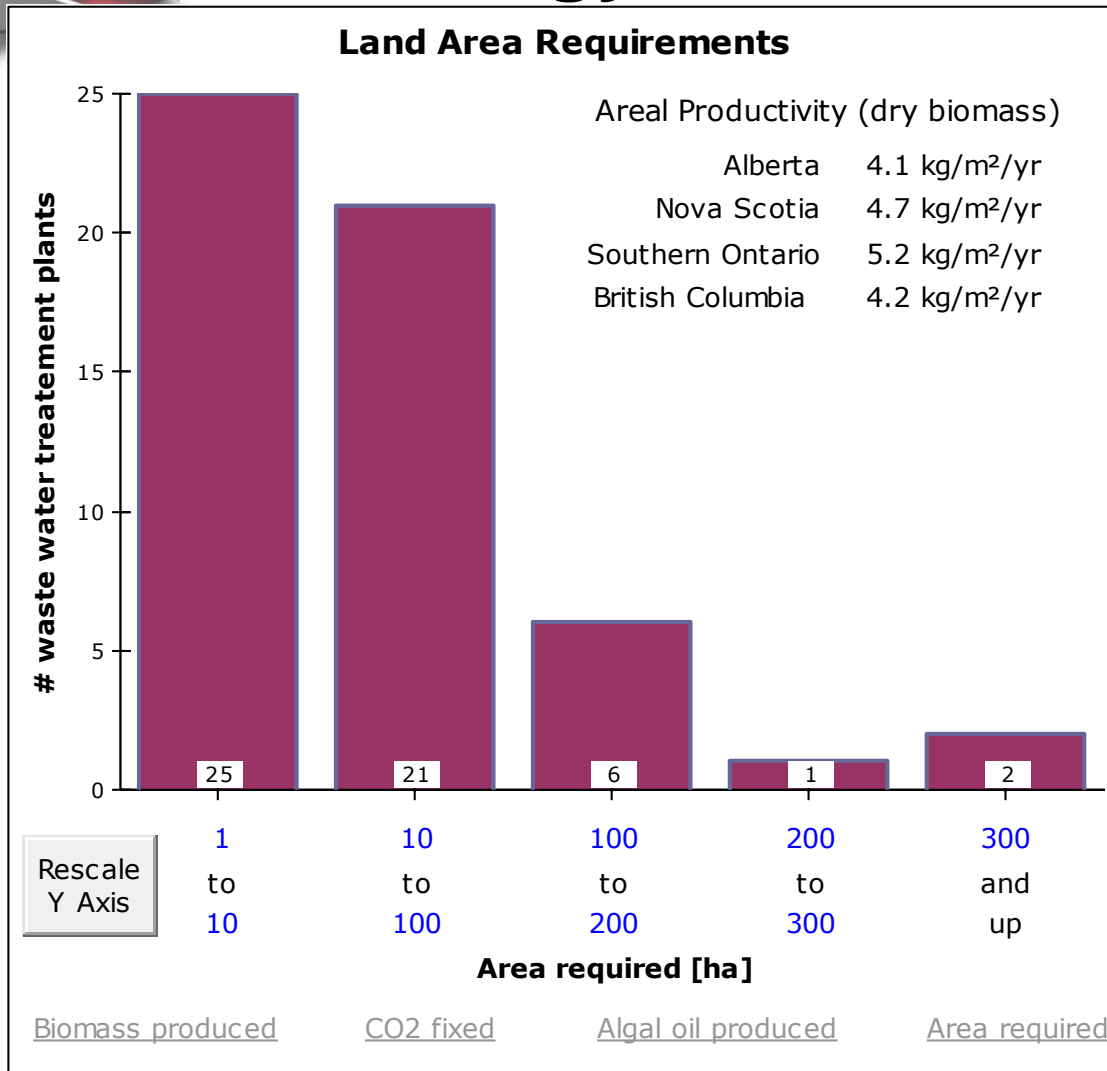

Histogram of # of wwtps that could produce a given range of biocrude, and how much land that would require

Sum of area required by largest 77 WWTPs: 3,605 ha



Land availability (Canada model)

Connect nutrient
information and energy
information with land
availability

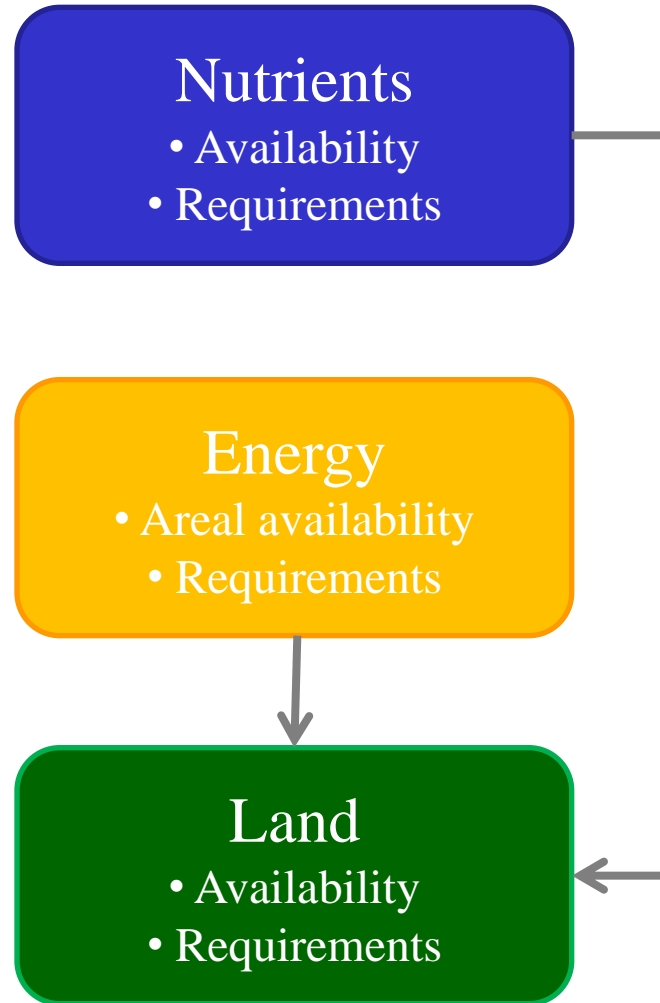

Land Availability Module

- Non developed land of less than 1% slope classified in GIS.
- (Based on land use, not land ownership due to data availability.)
- Model selects a contiguous area of sufficient size that minimizes costs to move nutrients from NP source and CO₂ source.

1. User selects WWTP for a given region from dropdown



Nova Scotia WWTP Selector	
Kings County	
45°4'19.92"	-64°27'34.92"
N load	52 tonnes/yr
P load	? tonne/yr
To land parcel	18 km

2. Model selects closest land-CO₂ source combination, displays essential properties, and maps all three locations



CO ₂ Source	
(selected automatically based on WWTP selected at left)	
44°40'48"	-63°36'
CO ₂ Emissions	9.9e5 tonnes/yr
% CO ₂ Needed	0.11 %
To land parcel	62 km



Land Parcel	
(selected automatically based on WWTP selected at left)	
44°59'0.94"	-64°15'59.38"
Total area	88 ha
Area required	13 ha
Pot. biocrude	1,688 brls/yr

Land Availability Module

Select region:

[British Columbia](#)

[Alberta](#)

[Southern Ontario](#)

[Nova Scotia](#)

Nova Scotia WWTP Selector

Kings County

45°4'19.92"	-64°27'34.92"
N load	52 tonnes/yr
P load	? tonne/yr
To land parcel	18 km

CO2 Source

(selected automatically based on WWTP selected at left)

44°40'48"	-63°36'
CO2 Emissions	9.9e5 tonnes/yr
% CO2 Needed	0.11 %
To land parcel	62 km

Land Parcel

(selected automatically based on WWTP selected at left)

44°59'0.94"	-64°15'59.38"
Total area	88 ha
Area required	13 ha
Pot. biocrude	1,688 brls/yr

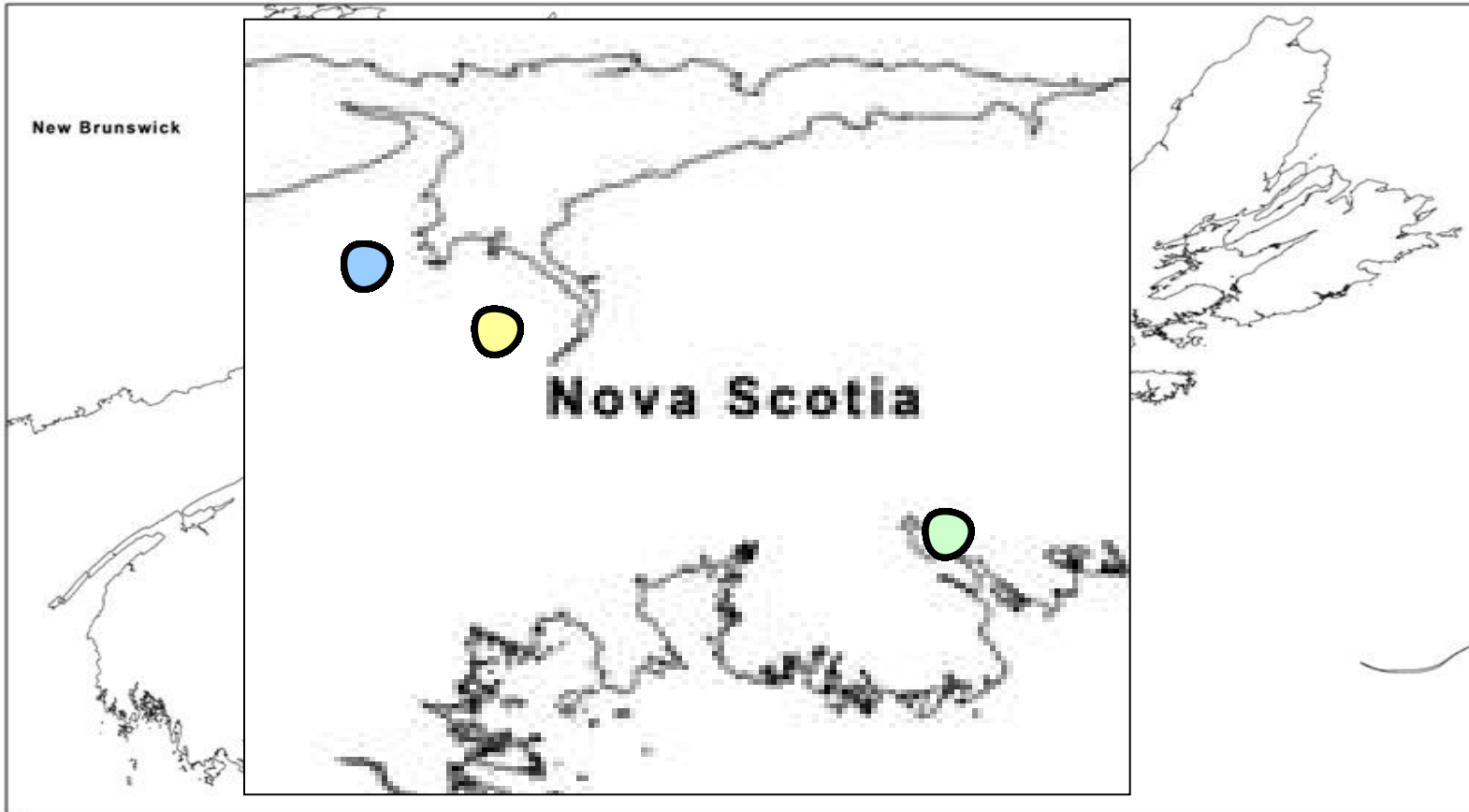

Model Results – Distances & Production Potential

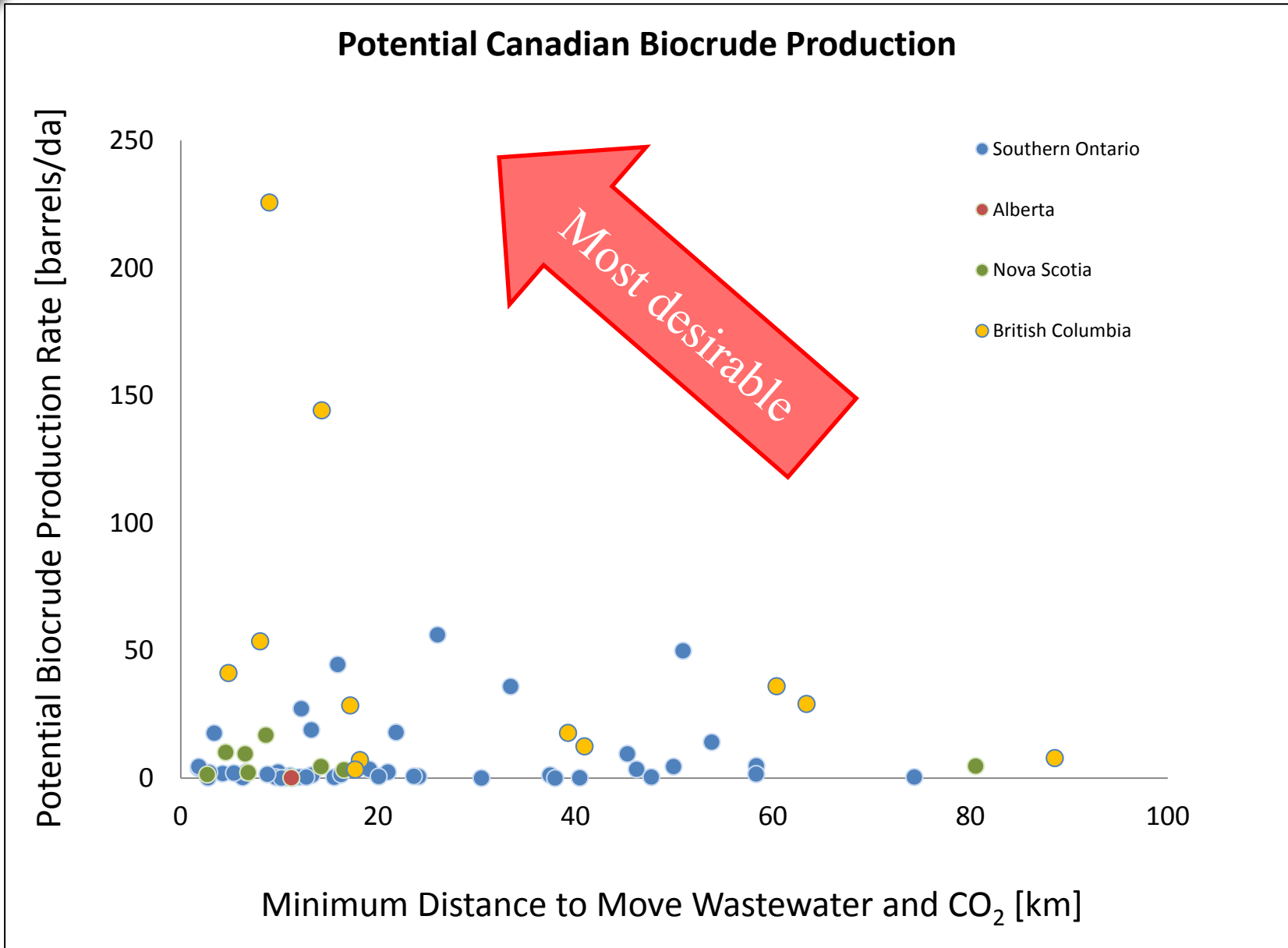

Model Results - Economics

Histogram shows minimum costs to grow algae using nutrients from waste water treatment plants and CO2 sources in four regions of Canada.

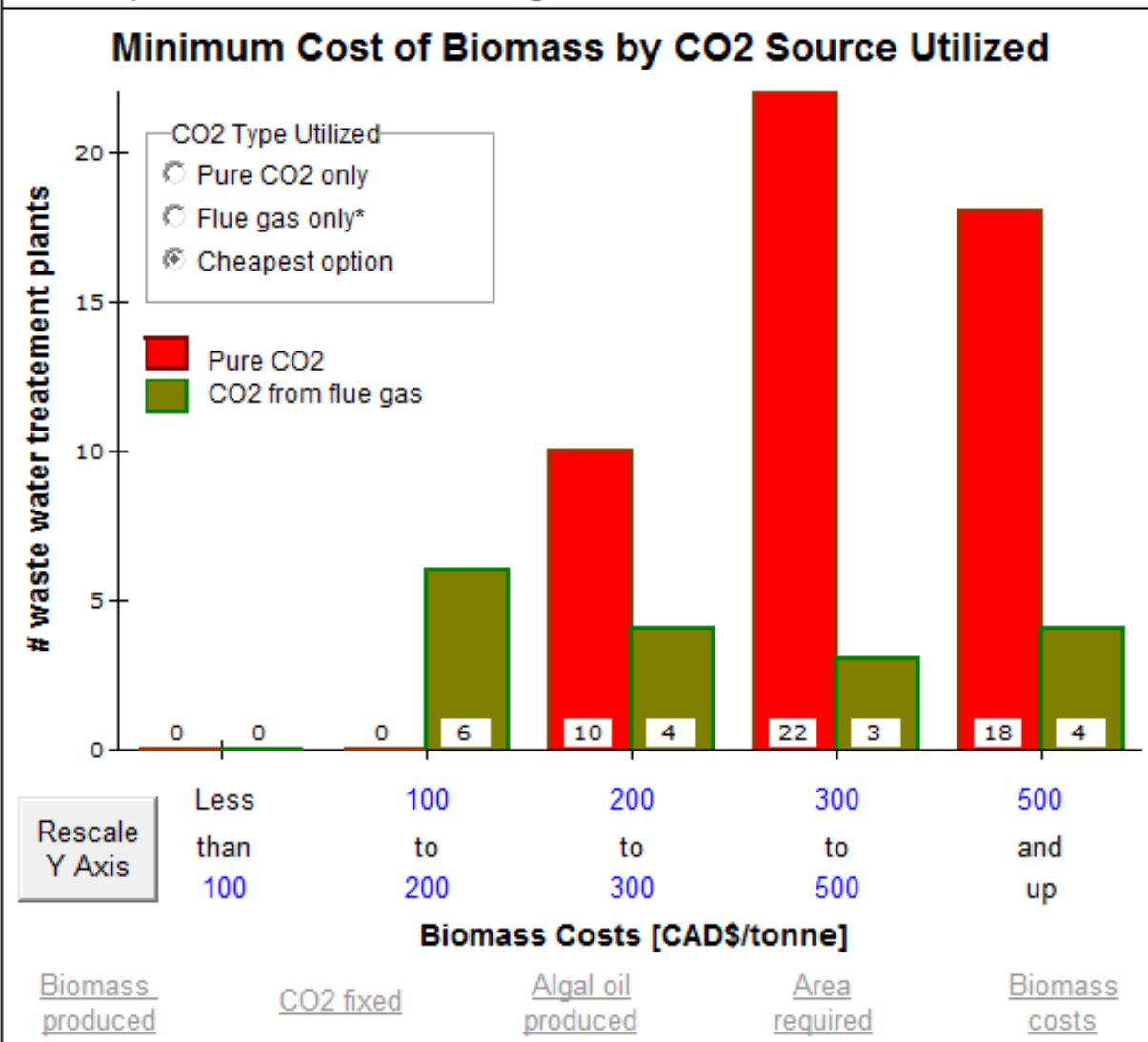

Model Results - Economics

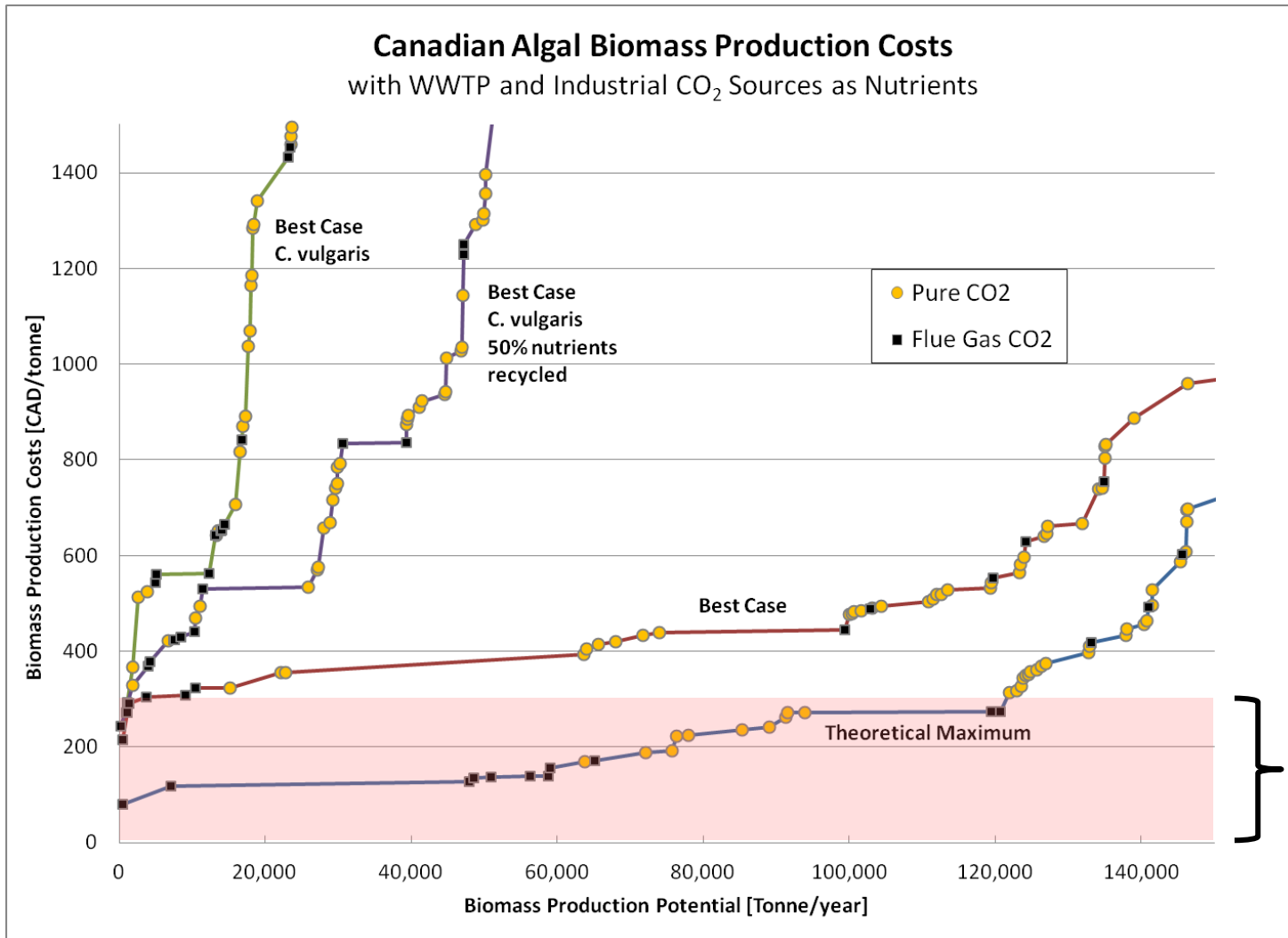

Promising
cost range



Conclusions & Limitations

- Results show that CO₂ is abundant compared to N and P
 - nutrient recycling may be critical to large scale feasibility
 - Database of CO₂ sites should be filled in with smaller sites
- Raw flue gas is the most economical source of CO₂, however it cannot be transported long distances. Water is heavy & expensive to move.
 - Truly co-located nutrient sources will be key to economic feasibility
- Challenges associated with seasonality of solar resource have not been considered.
- Challenges and opportunities associated with seasonal temperature requirements, and waste heat availability have not been considered.



Summary

- Project has successfully integrated spatial data and information into a GIS and systems model that evaluates algae cultivation and biocrude productivity potential for locations across Canada and Australia
- Nutrient recycling may be critical to large scale feasibility
- Contributes to end-to-end, systems understanding of resource needs required for large scale biofuel production
- Creates a framework for similar modeling in other regions and at other scales
- Highlights fruitful and productive collaboration between US national labs (SNL, NREL, PNNL) and international partners (National Research Council Canada, and Commonwealth Scientific and Industrial Research Organisation)

Questions?

Algae Molecular Composition per Atom P

Adjust numbers in blue. Default for C, N, P is "Redfield ratio". Default for H and O compared to C from Bayless et al 2003.

P 1 O 59 N 16 C 106 H 191

Nutrient Uptake Efficiencies & Recycle Rates:

Nutrient	Uptake Efficiency	% Recycled
Nitrogen	100 %	0 %
Phosphorus	100 %	0 %
Carbon	100 %	0 %

If nitrogen load data are available, or phosphorus load data are available, but not both:

- Assume missing constituent is unlimited
- Do not calculate productivity potential for that nutrient source

Max distance to move CO2

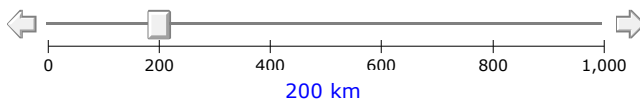

Nitrogen & Phosphorus sources from the following territories:

ACT NSW NT QLD SA TAS VIC WA

Potential CO2 Fixed

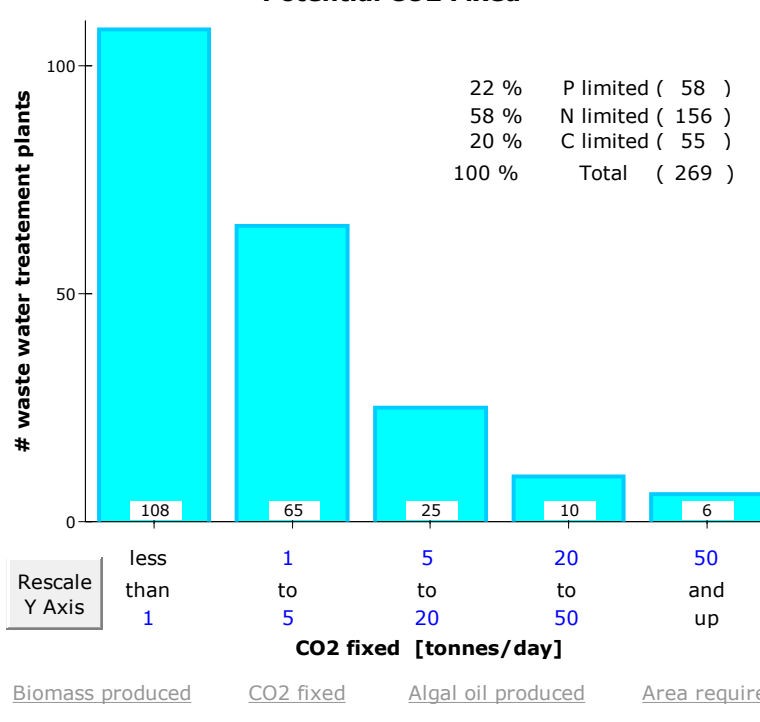

Potential CO2 fixed at largest 1 N-P sources 422 tonnes/day



Map points



Plot progress

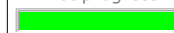

View Map of:

Biomass produced
CO2 fixed
Algal oil produced
Area required

jdroach@sandia.gov